



Data Sheet Wöhr Parklift 411/4

dependent parking
For permanent user only!*

* In case of short time user (e.g. for office-, hotel-, commercial building) only possible on lower platform and only if technically adjusted, ask WÖHR! Or with attendant or valet parking both levels are possible for short time user.

Load per platform max. 2000 kg (load per wheel max. 500 kg).

Dimensions in cm

Parklift 411/4

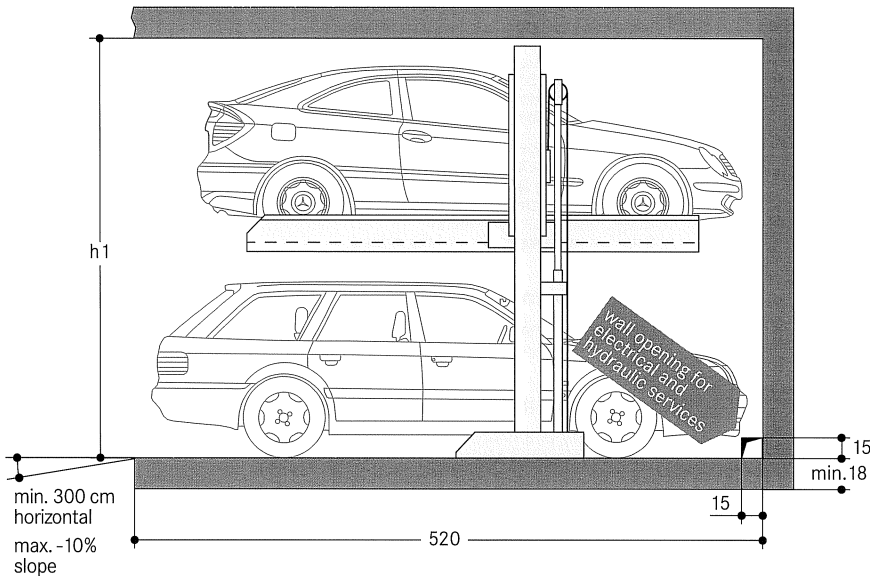

Standard type

	Parklift 411-155	Parklift 411-165	Parklift 411-175
Height h 1* single unit	320	330	340
Car height lower level	150	160	170
Car height upper level*	150	150	150

* With greater h1 height, higher cars can be parked on the upper platform

Comfort type

	Parklift 411-185	Parklift 411-195	Parklift 411-205
Height h 1* single unit	350	360	370
Car height lower level	180	190	200
Car height upper level*	150	150	150

* With greater h1 height, higher cars can be parked on the upper platform

Width dimensions

Single unit

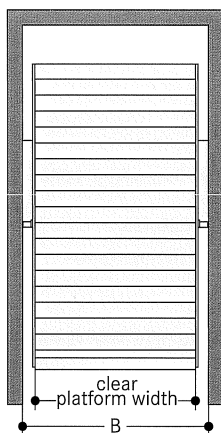

Space required B	gives clear platform width
245	210
255	220
265	230
275	240
285	250

Units in a row

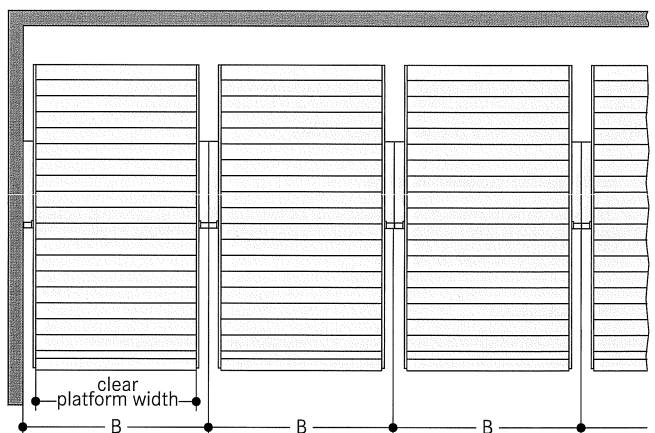

Notes

- Car width max. 190 cm with platform width of 230 cm. Smaller platform width does reduce the max. car width accordingly! For cars with two outside mirrors, a minimum platform width of 250 cm is recommended.
- According to ISO 3864 the floor has to be marked with 10 cm wide yellow-black stripes at a distance of 100 cm from the platform edge by the purchaser (see "statics and construction requirements" on page 2).
- The manufacturer reserves the right to modify or alter above specifications.



Electrical data

Item	Performance	Quantity	Designation	Position	Frequency
1	by customer	1 unit	electric meter	in the feed cable	
2	by customer	1 unit	fuse or automatic circuit breaker 3 x 16 A slow blow acc. to DIN VDE 0100 p. 430	in the feed cable	1 per power pack
3	by customer	as locally required	acc. to local power supply regulations 3 Ph + N + PE*	feed cable to main switch	1 per power pack
4	by customer	each 10 m	foundation earth connector	corner pit floor/rear wall	
5	by customer	1 unit	equipotential bonding acc. to local requirements	from foundation earth connector to Parklift	1 per Parklift
6	by customer	1 unit	marked main switch, lockable to prevent unauthorized switching on	above operating device	1 per power pack
7	by customer	10 m	PVC control cable with marked strands and protective conductor 5 x 1,5 ²	from main switch to hydraulic power pack	1 per power pack

Items 8–16 are included in Wöhr's scope of delivery unless otherwise specified in the offer/order.

* DIN VDE 0100 part 410 + 430 (not under permanent load) 3PH+N+PE (three-phase current) Note: Where a door is used to close the garage, the manufacturer of the door must be consulted before the electric cable is laid.

The electrical components supplied by the manufacturer must be connected in accordance with the appropriate wiring diagram and local regulations. German VDE electrical requirements must be adhered to, in order to validate the TÜV tested circuit.

The electrical supply to the power pack(s) must be provided

prior to or during installation to enable our fitters to complete their work satisfactorily and to check the correct functioning of the units.

Parklifts has to be grounded to the foundation earth connector by customer. A foundation earth connector should be provided by customer each 10 m or acc. to local requirements.

Noise protection

Basis is the German DIN 4109 "Noise protection in buildings".

With the following conditions required 30 dB (A) in rooms can be provided:

- noise protection package from our accessory
- insulation figure of the construction of min. $R'_w = 57$ dB
- walls which are bordering the parking systems must be done as single wall and deflection resistant with min. $m' = 300$ kg/m²
- solid ceiling above the parking systems with min. $m' = 400$ kg/m²

At differing constructional conditions additional sound absorbing measures are necessary.

The best results are reached by separated sole plates from the construction.

Increased noise protection:

If increased noise protection must be provided planning has to be confirmed on a project base by Wöhr (bigger building measurements are required).

Temperature

The installation is designed to operate between +5° and +40°C. Atmospheric Humidity: 50% at +40°C. If the local circumstances differ from the above please contact Wöhr.

Hydraulic power packs

For the accommodation of the hydraulic power packs an additional space is required which will be determined during the verifications of the drawings, e.g. in a wall recess.

Dimensions

All dimensions shown are minimum. Construction tolerances must be taken into consideration. All dimensions in cm.

Conformity test

All our systems are checked according to EC machinery directive 98/37/EG and EN 14010.

Railings

If walkways are arranged directly to the side or behind the systems, railings have to be provided acc. EN ISO 13857 by client acc. to local requirements, height min. 200cm.

Installation diagram

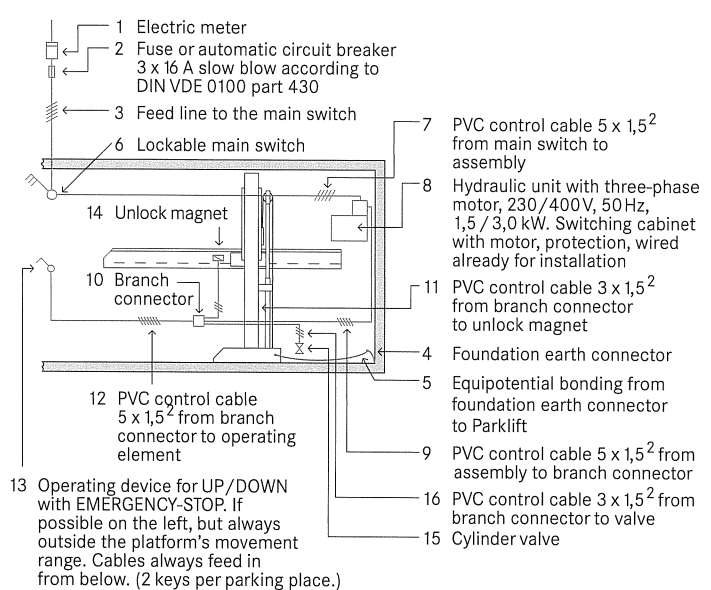

Maintenance

Regular maintenance by qualified personnel can be provided by means of an Annual Service Contract.

Protection against corrosion

Independent of a maintenance workings has to be carried out acc. to Wöhr Cleaning and Maintenance Instruction regularly.

Clean up galvanized parts and platforms of dirt and road salt as well as other pollution (corrosion danger)!

Pit must be always ventilated and deaired well.

Statics and construction requirements

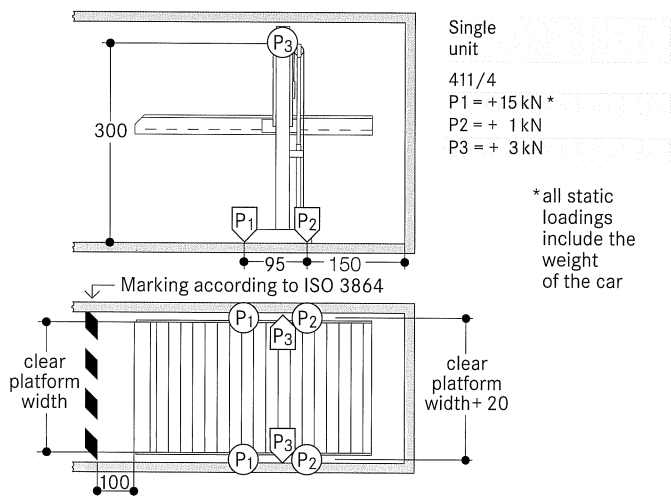

The units will be fixed on the anchor points with heavy duty anchor bolts to a depth of approx. 10–12cm.

Base plate thickness minimum 18cm! Concrete quality C20/25.

Special foundations are required with asphalt floors or paving-stones.

Notes

In case of lower cars with spoilers, contact Company Wöhr or local agent (see "clearance profile").

Clearance profile (standard car)

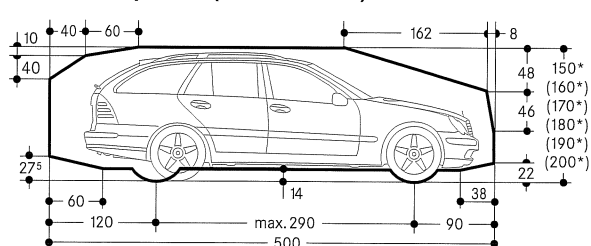

* The total car height includes roof rail and antenna fixture must not exceed the mentioned max. height dimension.